



SVS-VISTEK

# USERS MANUAL

## SVCam svs11002 and svs16000

### CameraLink "HR" series



**Digital Progressive Area Scan Camera**

**Version 2.4**

**Last Update 05.06.2013**



## **Contact:**

Feel free to contact us at:

# **SVS-VISTEK GmbH**

**Mühlbachstraße 20,**

**82229 Seefeld/Obb.**

**Tel. +49-(0)8152-99 85-**

**Fax +49-(0)8152-99 85-79**

**E-Mail [info@svs-vistek.com](mailto:info@svs-vistek.com)**

**Service contact:**

**E-Mail: [support@svs-vistek.com](mailto:support@svs-vistek.com)**

**For USA and Canada :**

# **SVS-VISTEK Inc.**

**5737 Ridge Creek Road  
Shoreview, MN 55126, USA**

**Tel: 651.756.8632**

**Fax: 651.756.7481**

**E-Mail [info-us@svs-vistek.com](mailto:info-us@svs-vistek.com)**

**Tel: 651.756.8632**

**Fax: 651.756.7481**

**E-Mail [info-us@svs-vistek.com](mailto:info-us@svs-vistek.com)**

# Index

<b>Chapter 1 – Introduction</b> .....	5
<b>Chapter 2 – Pin out and Installation</b> .....	6
2.1. Unpacking .....	6
2.2. Power Supply .....	6
2.3. Trigger connector .....	6
2.4. CameraLink connector.....	7
2.5. Installation .....	7
2.6. Available operation modes .....	8
<b>Chapter 3 – Technical Data</b> .....	8
3.0. Operation .....	8
3.1. CCD Sensor/2 tap-1 tap output .....	8
3.2. Signal conditioning .....	8
3.3. Interfacing/use of the “Convenient Cam” program .....	11
3.4. Mechanical and optical issues .....	23
3.5. Basic electro optical characteristics of Cameras .....	27
3.6. Environmental Tests .....	31
3.7. Spectral response curve .....	32
3.8. Comments on camera temperature .....	33
3.9. Comments on COLOR Version .....	34
<b>Chapter 4 – Miscellaneous</b>	
4.0. Proven Interfacing to framegrabber .....	35
4.1. Warranty Terms .....	36
Appendix A – Troubleshooting .....	37
Appendix B – Basic Pixel and Line Timing .....	39
Appendix C – Code Description for serial Camera Control .....	41
Appendix D – <b>For CameraLink Communication</b> .....	44
Making a serial control Interface to CameraLink Framegrabbers using. CameraLink DLL.	
Appendix E – <b>SAFETY INSTRUCTIONS</b> .....	45

## 1. Introduction

Thank you for purchasing a SVS-VISTEK product. SVS-VISTEK stands for reliable competence and customer oriented solutions in the field of professional machine vision systems. We believe that we are more than just a trade partner of machine vision components and we believe in sharing our years of development expertise with our customers. We offer single source solutions and are a one-stop shopping center for all questions concerning professional machine vision. As a consequence, our insistence on the highest quality has resulted in many companies worldwide that use our products and services with great success and satisfaction. Customers at home and abroad trust and rely on our know-how and experience.

The following types are covered in this manual:

svs16000 43,3mm diagonal CCD, 4904 x 3280 pixel, 10-Bit gray level resolution, up to 4 frames/sec ("2 tap, "F" version). Monochrome and color version.

svs11002 43,3mm diagonal CCD, 4008 x 2672 pixel, 10- or 12-Bit gray level resolution, up to 7.5 frames/sec ("Ultra high speed "). Monochrome and color version.

**For more information on the color versions, please see chapter 3.9.**

If you need modifications, we will be glad to offer you a custom camera suitable to your application.

## 2.0 Pinout and Installation

### Warning

The CCD camera is built with CMOS-LSI circuits. All internal electronics in the camera are sensitive to high voltage or electrostatic discharge. The camera can be destroyed if carelessly handled, so extreme care should be taken during set up and operation.

Do not expose the sensor to a direct laser beam as this could damage the sensor! **See Safety Instructions at Appendix E. Warranty will be void if not followed.**

### 2.1 Unpacking and Installation

- Camera
- Power supply (if ordered/option)
- User Manual
- CD with "Convenient Cam" program

**Install the camera in a appropriate, dry place. Use either Tripot or M3 front holes for mounting. Use good heat sinks to manage power dissipation.**

**Note that the "U" version has heat sink attached to the housing. To take advantage of the high frame rate a good airflow is highly recommended. If not done and operated in high temperature environment image distortions will be observed.**



**CAMERA CAN BE DESTROYED IF YOU DON'T FOLLOW THESE INSTRUCTION AND WARRANTY WILL BE VOID !**

### 2.2 Power supply

Male connector (Type TB3M micro switch)

PIN 1	+12V to +15 V DC
PIN 2	Reserved (Do not connect)
PIN 3	GND

Current consumption:

svs11000/16000	=1200 mA (typical "S" and "F" version)
	1500 mA ("U" version)



**Peak current on "Power on" up to 2 Ampere!**

### 2.3 Trigger connector

**TB 5M** connector, 5 pin, is used to give an external TTL-trigger-input (min. 5V TTL galvanic decoupled) to the camera, if it is not done per framegrabber.

#### TTL Exsync input to trigger camera (optocoupler input)

Pin 4: Tr - (Exsync GND)

Pin 5: Tr + (Exsync TTL)

See outline in chapter 3.4

**See chapter 2.6 Available operation modes**

## 2.4 “CameraLink” Connector

26 Pin connector MDR female (3 M): Base configuration with RS 232 communication

Pin	Name	Direction	Meaning
1	GND		
2	X 0-	Camera=>FG	Data
3	X 1-	Camera=>FG	Data
4	X 2-	Camera=>FG	Data
5	Xclk-	Camera=>FG	Transmitterclock/PVAL
6	X3-	Camera=>FG	Data
7	Ser TC+	FG => Camera	Camera control (RS232)
8	SerTFG-	Camera=>FG	Camera control (RS232)
9	CC1-	FG => Camera	Exsync
10	CC2+	FG => Camera	Prin (not used)
11	CC3-	FG => Camera	External camera clock
12	CC4+	FG => Camera	NC
13	GND		
14	GND		
15	X 0+	Camera=>FG	Data
16	X 1+	Camera=>FG	Data
17	X2+	Camera=>FG	Data
18	Xclk+	Camera=>FG	Transmitterclock/PVAL
19	X3+	Camera=>FG	Data
20	SerTC-	FG => Camera	Camera control (RS232)
21	SerTFG+	Camera=>FG	Camera control (RS232)
22	CC1+	FG => Camera	Exsync
23	CC2-	FG => Camera	Prin (not used)
24	CC3+	FG => Camera	External camera clock
25	CC4-	FG => Camera	NC
26	GND		

**Camera has a “BASE” configuration according to CameraLink definition. However, the output of the Truesense KAI 11002/16000 CCD is configured as a two tap for “T”, “F” and “U” version (11002 currently only).**

## 2.5 Installation

1) Install camera in the desired location. You can use the ¼ “ tripod adapter or use the 4 xM3 holes in the front plate of the camera.

 2) Connect the power supply. If you have ordered a P/S, connect it to the 3 pin connector on the camera. If you use your own power supply (must be 12V DC) make sure you connect it to Pin1 (+12V) and pin 3 (GND). **If you – by mistake – supply line with GND pin the camera can be damaged!** If power supply was ordered, do not modify it.

Connect a CameraLink cable to your framegrabber. Please note that cable length should not exceed 10 m for these camera (“F” version and higher clocked cameras). A **REPEATER** is available to extend cable length. Consult your local distributor!

## 2.6 Available Modes of Operation

### General:

**All modes are set by the serial interface which connects via CameraLink standard cable.** The default factory setting is **free running** using the internal microcontroller for exposure control: Mode 0. The Gain of the signal can be adjusted software wise by a factor of 2. Please note that noise also is amplified. **Higher Gain is possible but not specified!** The Gain default setting is 1.0.

### Mode 0: Free running using Microcontroller

In this mode the camera creates all sync signals itself. There is no need to trigger the camera (by EXSYNC) in order to get data. **The Exposure time can be set by using the serial Interface of the PC.** The enclosed program allows the user to set the values from about 10.000/sec (1 line duration) to one frame duration.

Exposure time can be changed online during operation.

### Mode 1: Triggered and using Pulse width of Exsync

In this mode the camera is waiting for an external trigger which causes the integration and read out. The exposure time can be varied by the length of EXSYNC between the high going edge and the low going edge. The Time settings in the control menu are not activated. This mode is useful in applications where the light level of the scene changes during operation. A frame to frame variation is allowed. Trigger can be fed via Framegrabber (if supported) or by TTL(min 5 V) into on TB 5 connector (**see 2.3**)

### Mode 2: Triggered and using Microcontroller

The frame rate is determined by the number of Exsync pulses per time. With each positive transition (going high) the camera will readout a frame. The Exposure time is set as mentioned in Mode 0. The maximum exposure time is 65535 line durations, Minimum is 1 line duration. Trigger can be fed via framegrabber (if supported) or by TTL into on TB 5 connector (**see 2.3**) (**see 2.3**) Exposure time can be changed online during operation.

### Software:

The camera comes with “**Convenient Cam**” program allowing interactive access to above parameters. This software is available for WIN XP.

The color version will come on request with free software algorithm which will allow processing of the color image in the PC. This must to be done in order to interpolate the colors for each pixel. Please note that no responsibility can be taken for the algorithm. It might be necessary to change the algorithm according to the application. **See chapter 3.7.**

## 3.0 Operation

### 3.1 Sensors:

- Truesense KAI 11002M/C 4008 x 2672 Pixel Class I
- and KAI 16000M/C, 4904 x 3280 Pixel Class I

**Note following cosmetic specs for Truesense CCD:**

#### KAI 11002M



- Cluster allowed. Cluster may contain up to 20 pixel out of PRNU spec.
- 20 cluster allowed
- Point defects: 1000 pixel dead or out of PRNU spec. (color version up to 2000)
- Column defects: Monochrome = 0.



**Color: Up to 10 columns. Column may contain more than 10 pixel dead or out of PRNU.**

**Class II is standard for color and exhibits in addition column defects**

### KAI 16000M/C



- Cluster allowed. Cluster may contain up to 20 pixel out of PRNU spec.
- 30 cluster allowed
- Point defects: 1500 pixel dead or out of PRNU spec. (color version up to 3000)
- Column defects: Monochrome = 0.  
Color: Up to 15 columns. Column may contain more than 10 pixel dead or out of PRNU

**First AND Last 300 columns out of PRNU spec of rest of CCD. They will not be saturated as other columns with same amount of light! This can be compensated to some extent with higher Gain. However noise will be increased. More details are available in the KAI 11002 and 16000 spec sheet.**

Spectral range: 400 - 900 nm (B/W), COLOR version: RGB Bayer Mosaic Filter, **see 3.7**

### 3.1.2

#### Readout from CCD/svs11002 and svs16000

The output for the “U” and “F” version is as follows:

2 taps are read out and the right half of the image is mirrored starting at 1<sup>st</sup> line pixel # 2004 through 2672 (11 megapixel CCD). See image below. As a result either framegrabber or PC memory must reverse the 2<sup>nd</sup> half in order to get a complete image as it is for the “S” version. There the complete image is read out as usual with one tap CCD.

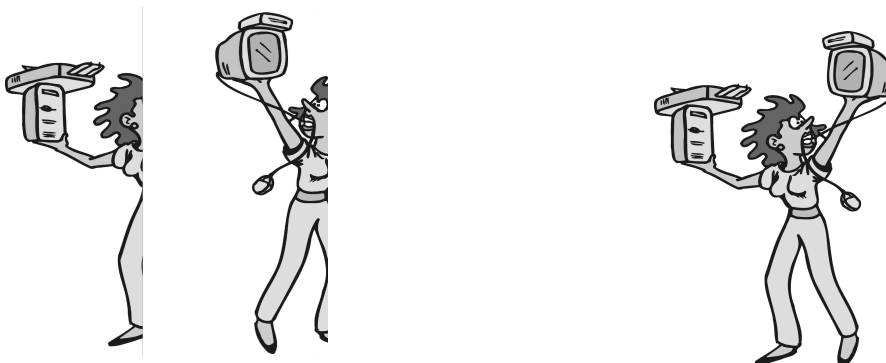

2 Tap output “T”, “F” and “U” version

1 Tap output “S” + “O” version

**A tap balancing dll for “ Automatic tap balancing” is available ( for programming engineers)**

### 3.2 Signal conditioning

The analog output of the sensor is conditioned by Correlated Double Sampling (CDS) for optimum S/N ratio. dark level drift is compensated by an “auto zero” amplifier circuit and fed into a video ADC with 10- or 12-Bit resolution.

This page is left blank

### 3.3 Interfacing/use of the “Convenient Cam“ program



**svs16000XXCP will ONLY work with ConvCam3.0!  
11 megapixel camera works also with 2.6!**

The camera can be operated in a free running mode as well as in a synchronized and triggered mode. An exposure control can be set by serial communication or by using the pulse width of the trigger signal (Exsync).

For PC support a software disk, “Convenient Cam”, is enclosed which allows setting of parameters via a serial port. For OEMs the source code is available on request. A DLL is delivered with the program and **MICROSOFT® DOT NET Framework 2.0** is required is to get the “Convenient Cam 3.0” program working.

**See screen shot of the menu**

The camera can also be operated with any terminal program. See “Command Overview.doc” If you have installed the camera and connected power, you can install the program to do the first test. **The program will fail to start if it can't find the DLL! Check the Readme file and Load DLL in ConvCam menu.**

#### **FIRST: Install the ConvCam program**

**For svs16000 you need ConvCam 3.0 or higher and THAN:**

You will have



- a) Already Dot Net on you PC or
- b) Make sure that a Internet connection is present during installation

**If you have a svs11002 camera it can still work with ConvCam 2.6.  
See older version of this manual.**

#### **The “Connection“ Folder**

**The “Set Port No”:**

Tick always to “Enable CameraLink” for communication via framegrabber.

**Load CameraLink DLL** if communication fails in the beginning

**The serial Port (in case above does not work)**

Set COM port for serial control which will work with your framegrabber via CameraLink. Tick “enable serial port”. If you get error messages starting the software make sure that your camera is connected to the chosen port (usually com 3,4,5,6, ...due to CameraLink standard).You can change the port with the “COM:”-field **if the CameraLink will not work immediately.** (If supported by framegrabber manufacturer)

**Port info:** can display framegrabber port used (If supported by framegrabber manufacturer)

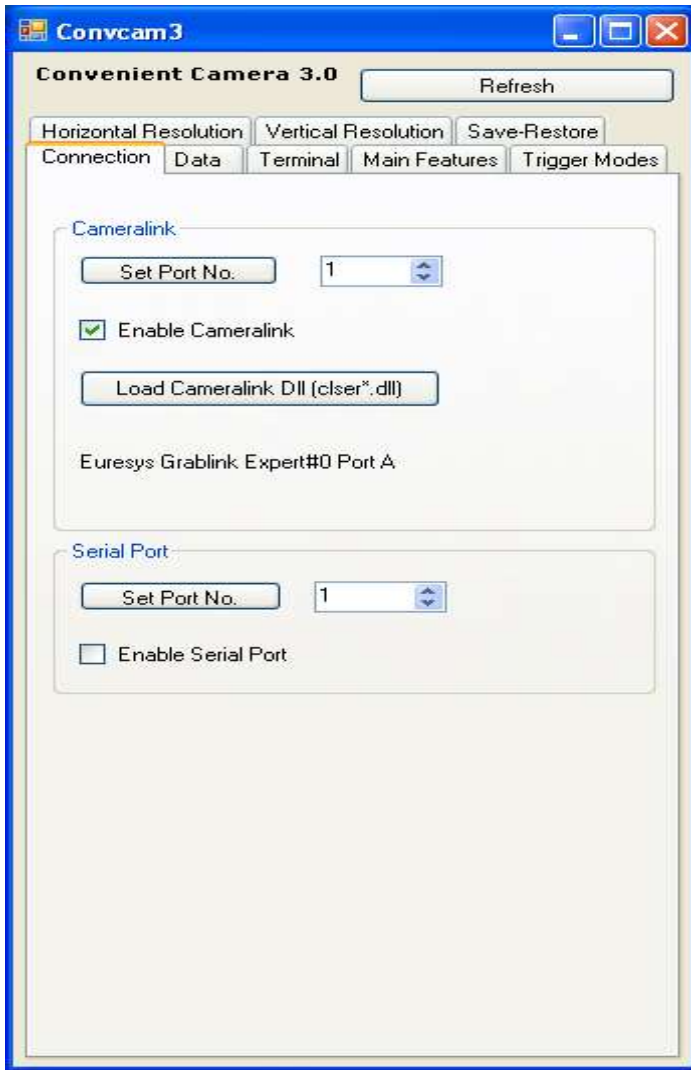

## The “Main Features” Folder

The program will identify the used camera type (top). And S/N number (bottom)

### **The ”Exposure time“ field**

Exposure time: the exposure time can be set in  $\mu\text{sec}$ . The min exposure time is about 50  $\mu\text{sec}$  (depending on the camera type and speed). The longest is about several seconds (triggered modes). Due to the internal timing of the camera the program will adjust the values to the appropriate values. Exposure time can also be expressed as “line time” because the minimum time set is the duration of one line. If you use this field the exposure time in  $\mu\text{sec}$  will change automatically and vice versa.

**The “Gain” and “Offset“ field**

The default gain setting is “1.0”. You may change the gain up to factor 3.0 (or higher) in steps of 1/10<sup>th</sup>. Note that the dark offset will increase and dynamic range will not be improved! For good image quality do not increase gain more than factor 2, because the noise is also amplified.

“Gain value” allows finer adjustments than “gain factor”.

**“F” , “U” and “H” version of svs11002/16000:**

**Note that the CCD has 2 outputs. Therefore there are a “right” and a “left” image half. If you use the slider both channels are amplified. However depending on the amplifications there might be different values necessary in order to make both channels equal. Fine tuning in “Gain Value” is necessary. There are about 768 possible steps to adjust. It is still possible to have 1-2 counts difference between both image halves. This is NOT a camera problem and must be adjusted by an experienced user. Same is true for the offset.**

Dark level offset adjustment is possible. Please note that factory adjustment is optimized for S/N ratio and sensitivity. You may lose dynamic range. Alter only if you operate at high temperatures like +40 °C. It can be altered for each channel separately.

**The “Snapshot Button” (svs16000 only)**

**Will read ONE image only if camera is set to “free running” or” triggered with internal expo control” mode.**

## The “Frame Rate” field

In “free running” mode (default ex factory) you can adjust the framerate.

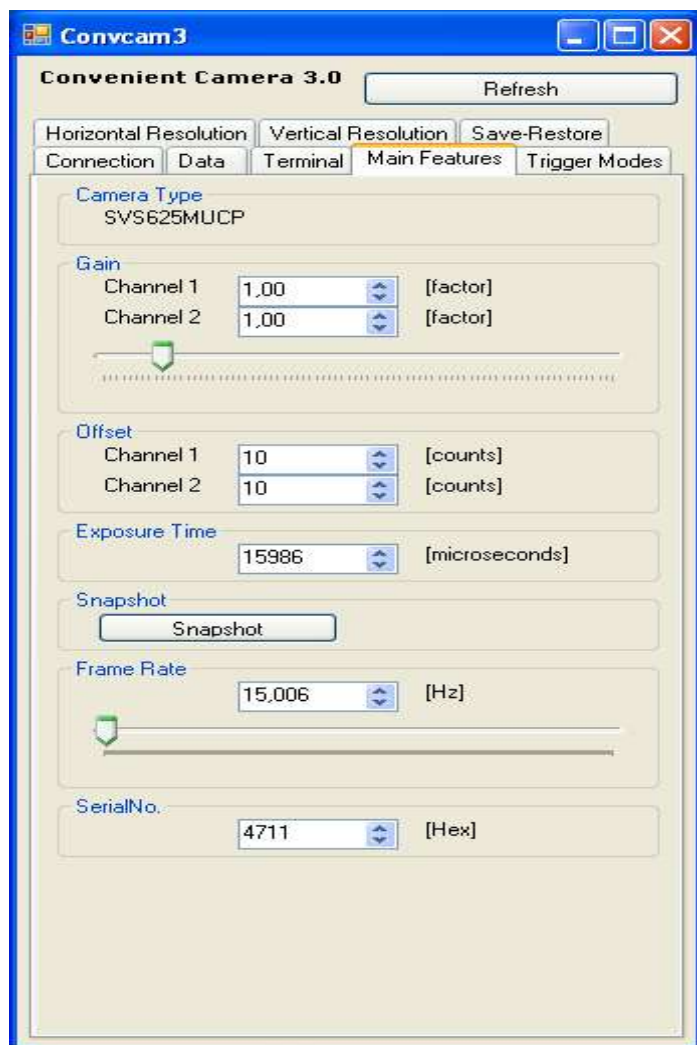

## The “Save Restore” folder

### The “Reset Camera” button

If you have troubles during configuration, you can set the last saved configuration clicking this button (you could also switch power off and on and also and click on “read status” again).

### The “Save to EEPROM” button

If you have configured your camera successfully you can save the actual configuration in the EEPROM of the micro controller. Every time the camera is connected to power it will start with this configuration. Ensure that your camera is running correctly before you click this button!



## **The “Trigger Mode” folder**

### **“Free running”, Mode 0**

At the first installation it should be mode 0 (factory default). This means the camera is free running with maximum frame rate and exposure time is controlled by the internal micro controller. Exposure time can be set via serial communication (ConvCam.exe, see “Main Features”). No further external signals.

### **“Opto Triggered”, external exposure control, Mode 1**

If you want to trigger the camera and determine the exposure time by the pulse width of Exsync, choose this mode. Then apply a Exsync signal at the appropriate pins e.g. on pins of TB 5 connector. The rising edge of the pulse the camera will start exposure time. The exposure time ends with the falling edge of Exsync.

Please check the timing diagram in the appendix of this manual.

### **“Opto Triggered”, internal exposure control, Mode 1**

If you want to trigger the camera and determine the exposure time by the internal micro controller choose this mode. You still need to use the Exsync signal (min 5 V TTL) in order to trigger the camera (see “Trigger”-buttons below). It will initiate exposure by the rising edge of the pulse. Apply a Exsync signal at the appropriate pins e.g. on pins of TB 5 connector Please check the timing diagram in the appendix of this manual.

### **“LVDS Triggered”, external exposure control, Mode 2**

If you want to trigger the camera via framegrabber and use pulswidth control controller then use this mode. Exposure time is set via CameraLink through you framegrabber. (Contact your framegrabber supplier for how to feed signal into the grabber). The framegrabber generates the pulse width of the exposure time. With the rising edge of the pulse the camera will start exposure time. The exposure time ends with the falling edge of Exsync.

### **“LVDS Triggered”, internal exposure control, Mode 2**

If you want to trigger the camera trigger the camera via framegrabber and use the convenient exposure time control of the micro controller then use this mode. You still can use the serial port for setting exposure time (see “Main features”-folder).





## The vertical (partial scan) and horizontal resolution Folders

### The “Binning” field: readout modes

You can choose different resolutions

No Binning: Full resolution: horizontal x 1, vertical x 1 (default setting)

H 2 x V 2 x: Vertical 2 x and Horizontal 2 x at the same time:

Resolution: horizontal x ½, vertical x ½

Sensitivity is 4 x, pixel frequency is halved, max. frame rate is almost doubled

“Binning Off” sets the camera to full resolution either in vertical or horizontal resolution.

**Note: Horizontal can not be changed in increments. It is for INFORMATION only!**

If you need other binning mode configurations consult factory or your nearest distributor. **Using binning with a color version of the camera will cause incorrect colors and strange effects!** However, for fast focusing it might be useful.

### Vertical Resolution=Partial Scan

**Partial scan of lines can be chosen in steps** of 19/32 lines (camera type dependent). As an example: The minimum number and starting point are 17 lines. The max. number is 2672. As a result the frame rate of the camera will be increased when resolution is lower (e.g. 4008 x 1024 yields 9 fps). Partial scan is done starting in center of the imager.

If you need other readout mode configurations consult the factory or your nearest distributor.

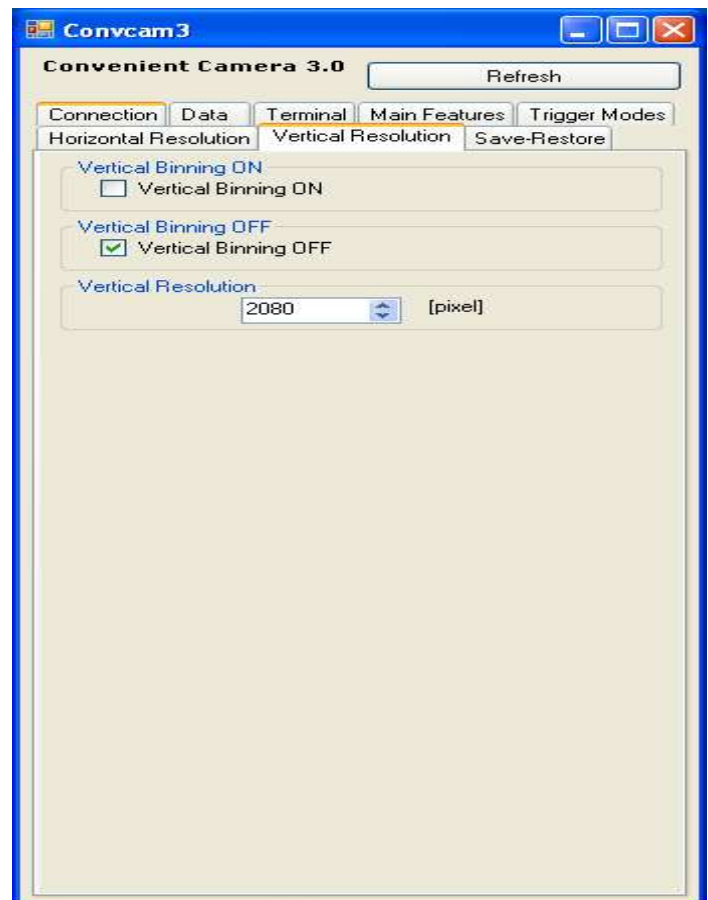
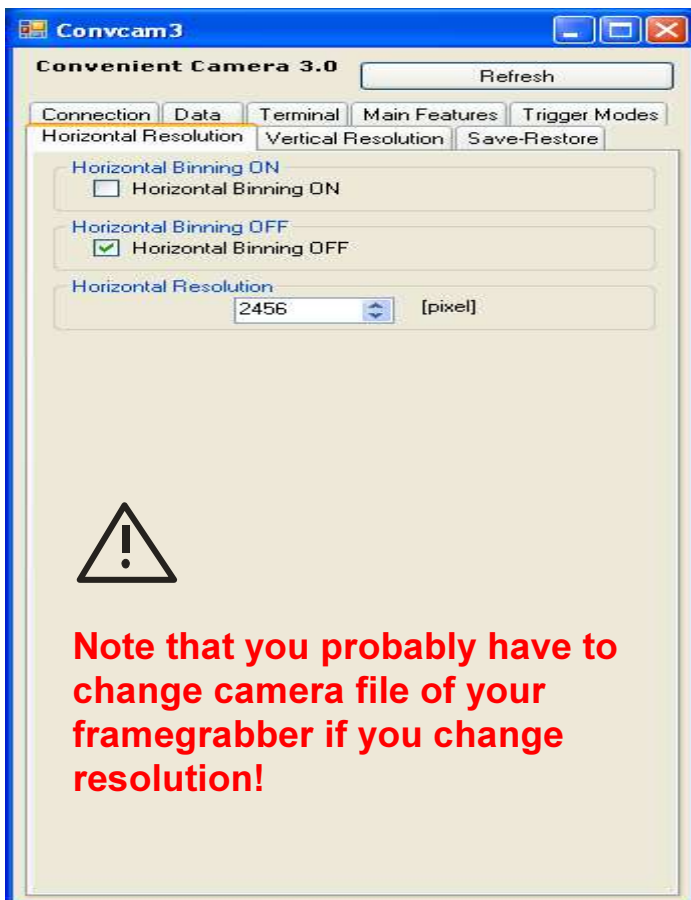

**Note that cameras using 14 bit ADCs a pseudo binning in horizontal resolution can only be achieved by activating the DAVAL signal of the frame grabber. In combination with vertical binning the result looks like 2 x 2 binning with only 2 times the sensitivity.**

## The Data Folder

### **Save configuration to file**

Allows to “**Save**” different configurations and upload them with “**Load**”

### **Create Log file**

Creates a log file in a directory (e.g. program/svs-vistek/convcam)

It store all changes made to the camera during operation period.

### **Close Logfile**

Stops the command protocol.

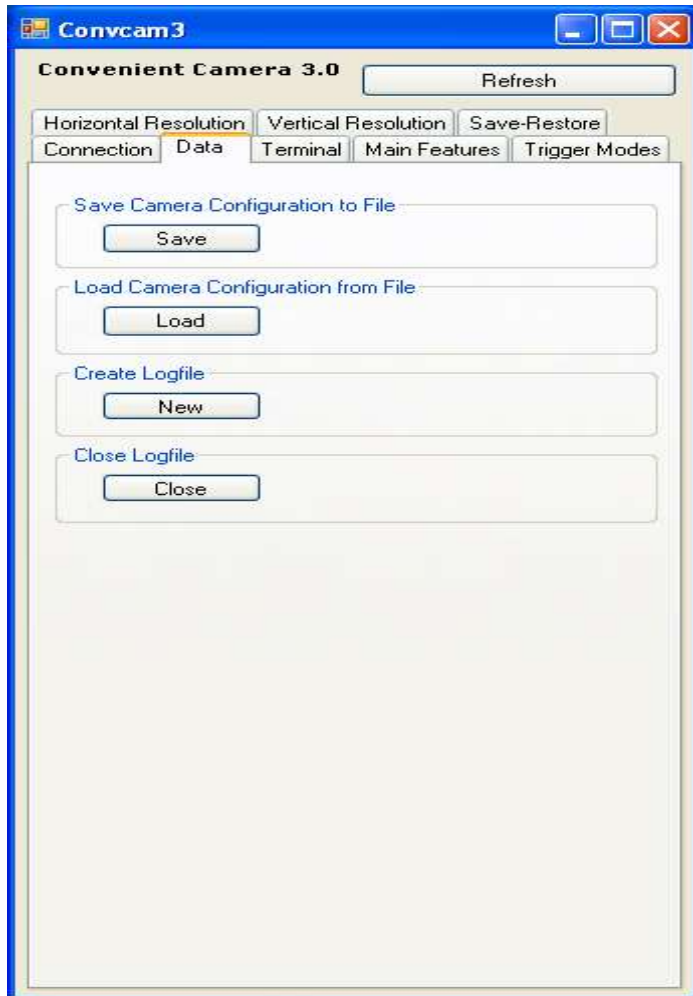

## The Terminal Folder

In case you want to make a serial connection to the camera via CameraLink you can type in the commands listed in Appendix C Of this manual.

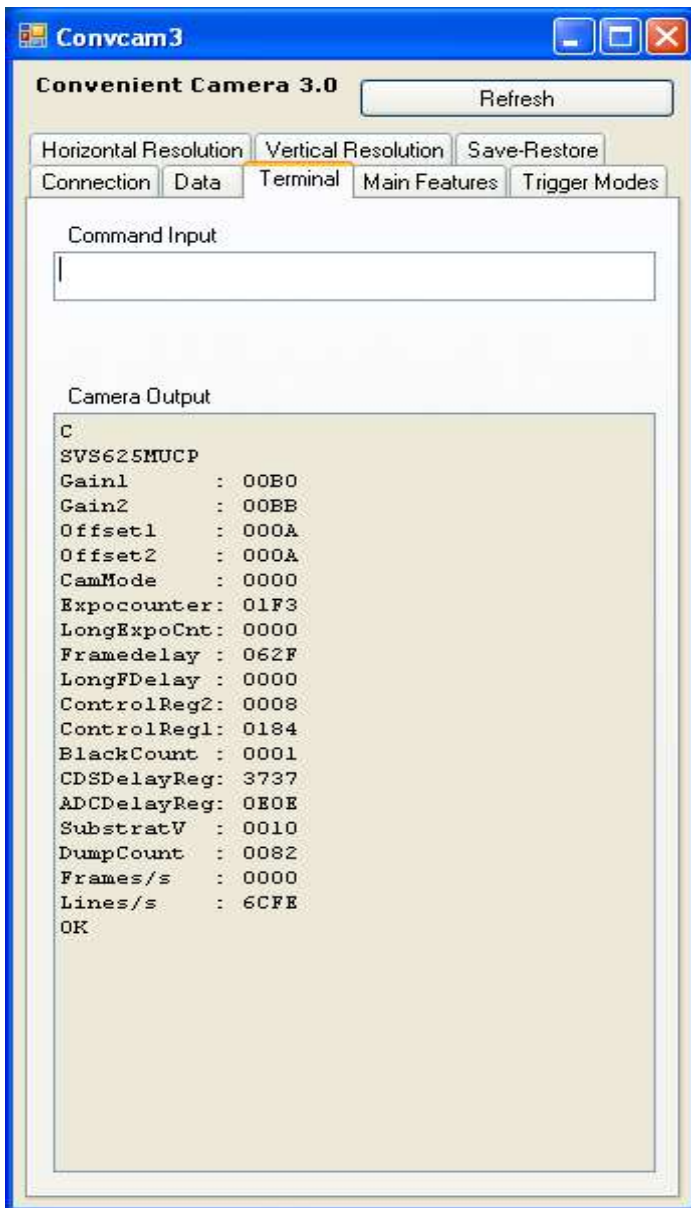

## The PIV Folder

Activate PIV mode if you need to take 2 images within minimum time

### **PIV-MODE SVS11002xTLCPC**

SVS11000xTLCPC cameras have the possibility to do 2 images within a extreme short period of time. This can be done either in the mode „triggered with external exposure“ (via pulse width of the Exsync signal) or alternatively „triggered with internal exposure“ ( set via internal microcontroller) This is useful for "particle image velocimetry" ( PIV-Mode).

The time between 2 image acquisitions can be shortened to minimal 30  $\mu$ s + flash duration time. The first exposure starts 5  $\mu$ s after the camera has received the positive slope of Exsync. It ends 120  $\mu$ s after the negative slope.

The 2nd exposure takes place **without exposure time control (!)**. During the same time the 1<sup>st</sup> image is read out. The 2<sup>nd</sup> exposure starts automatically 150  $\mu$ s after the negative slope of Exsync signal and ends after the complete read out of the 1<sup>st</sup> image. (Usually a flash determines the exposure time of the 2<sup>nd</sup> image).

Now the 2<sup>nd</sup> image follows immediately. During the read out of the 2nd image the camera can **not** take images until the next Exsync signal (positive slope) arrives and initiates the next exposure cycle.

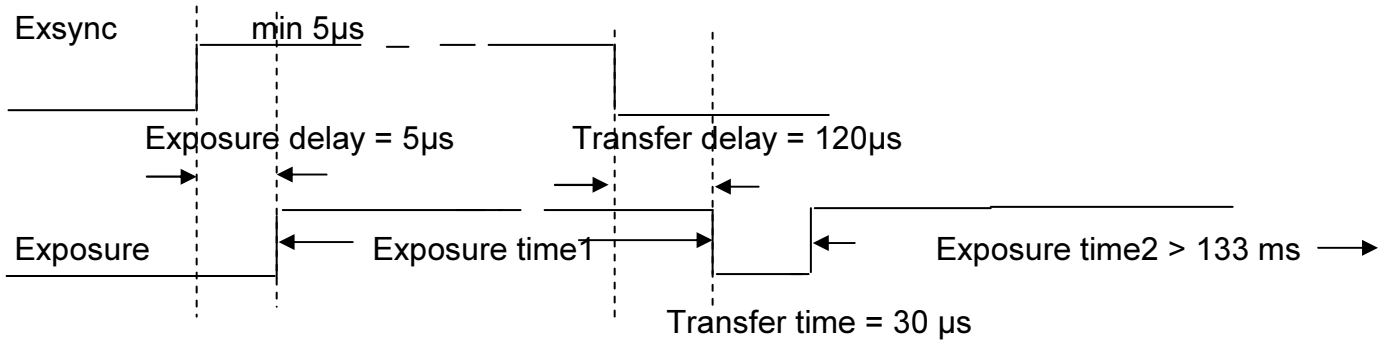

The trigger frequency at 48MHz pixel clock is limited to max. 3.75 Hz = 7.5 fps.

The stated delay values are independent from pixel clock frequency.

The maximum frame rate is proportional to pixel clock.

**No trigger signal** must be given **during power up** of the camera. Wait about 2 seconds!

Without PIV-Mode enabled, all camera modes like “free running “or “triggered with internal exposure control“ function as described in the manual.

## PIV-MODE SVS16000XTLCPC

SVS16000xTLCPC cameras have the possibility to do 2 images within a extreme short period of time. This can be done either in the mode „triggered with external exposure“ (via pulse width of the Exsync signal) or alternatively „triggered with internal exposure“ ( set via internal microcontroller) This is useful for "particle image velocimetry" ( PIV-Mode).

The time between 2 image acquisitions can be shortened to minimal  $26 \mu\text{s}$  + flash duration time. The first exposure starts  $5 \mu\text{s}$  after the camera has received the positive slope of Exsync. It ends  $200 \mu\text{s}$  after the negative slope.

The 2nd exposure takes place **without exposure time control (!)**. During the same time the 1<sup>st</sup> image is read out. The 2<sup>nd</sup> exposure starts automatically  $226 \mu\text{s}$  after the negative slope of Exsync signal and ends after the complete read out of the 1<sup>st</sup> image. (Usually a flash determines the exposure time of the 2<sup>nd</sup> image).

Now the 2<sup>nd</sup> image follows immediately. During the read out of the 2nd image the camera can **not** take images until the next Exsync signal (positive slope) arrives and initiates the next exposure cycle.

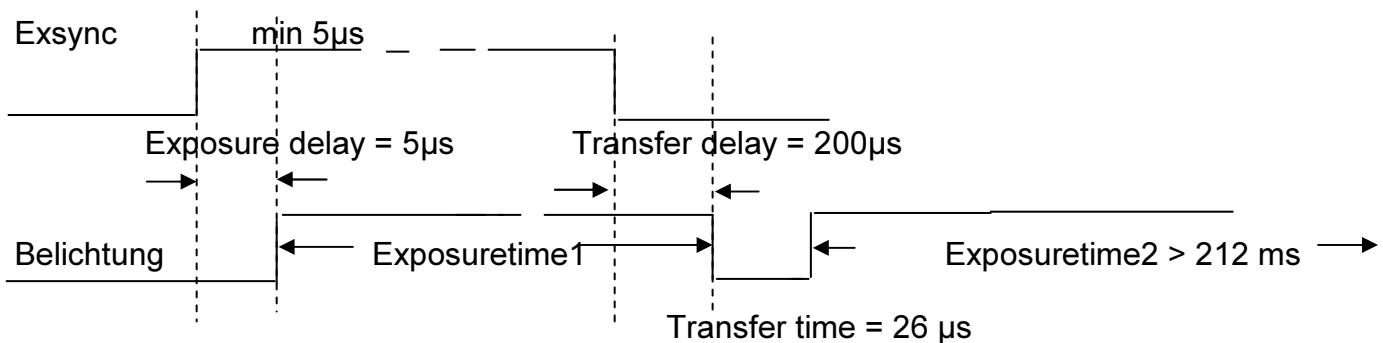

The trigger frequency at 48MHz pixel clock is limited to max.  $2.35 \text{ Hz} = 4.7 \text{ fps}$ .

The stated delay values are independent from pixel clock frequency.

The maximum frame rate is proportional to pixel clock.

**No trigger signal** must be given **during power up** of the camera. Wait about 2 seconds!

Without PIV-Mode enabled, all camera modes like "free running" or "triggered with internal exposure control" function as described in the manual.

### 3.4 Mechanical and optical issues

#### svs11002

Camera size: 65 x 67 x 45mm (without connectors and lens; "S" and "F" ONLY)  
65 x 82 x 45mm ("U" version with heatsink)

#### svs16000

Camera size: 65 x 67 x 43mm (without connectors and lens; "S" and "F" ONLY)

Weight: Approx. 300 gram

Front plate with M 42 x 1 threads or M 58 x 0.75 mount adapter.

**Distance from Chip surface to front plate: 11,65mm**

#### NOTE:



**Depending on focal length of the optics it might cause dark edges due to a loss of light in the corners. This is not a fault of the camera.**

**We recommend use of solutions from Schneider, Linos or others who offer interfaces to M 58 x 0.75 thread. F-Mounts work usually with focal length longer than 35mm. Due to micro lens on CCD chip strange effects like increased PRNU at the first and last 500 pixel can be observed. Do not use lenses which are intended for 1" CCDs.**

#### Views on svs11002 "S", "O", "F" and "H" Version (no heatsink)

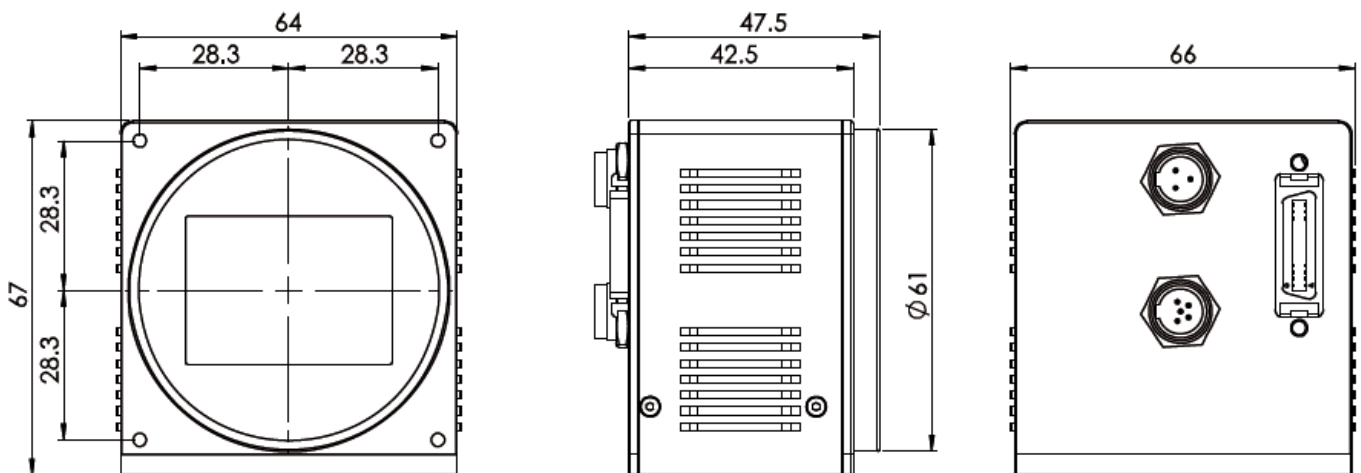

**Distance from Chip surface to front plate: 11,65mm**

MDR 26 female Connector  
Sync and Dataserial LVDS  
see Listing on 2.4.2  
Mating connector:  
3M

Part.-Nr of connector: 10126-6000EL

Part.-Nr of hood: 10326-A200-00

Power Connector:  
Pin 1: + 12V  
Pin 3: GND  
Pin 2: Reserved  
Mating connector: Switchcraft TA3F

Trigger Connector:  
Pin 4: TTL - (GND)  
Pin 5: TTL +  
Pin 1, 2, 3: Do Not Connect  
Mating connector: Switchcraft TA 5F

**Views on svs11002 "U" + "H" version only**

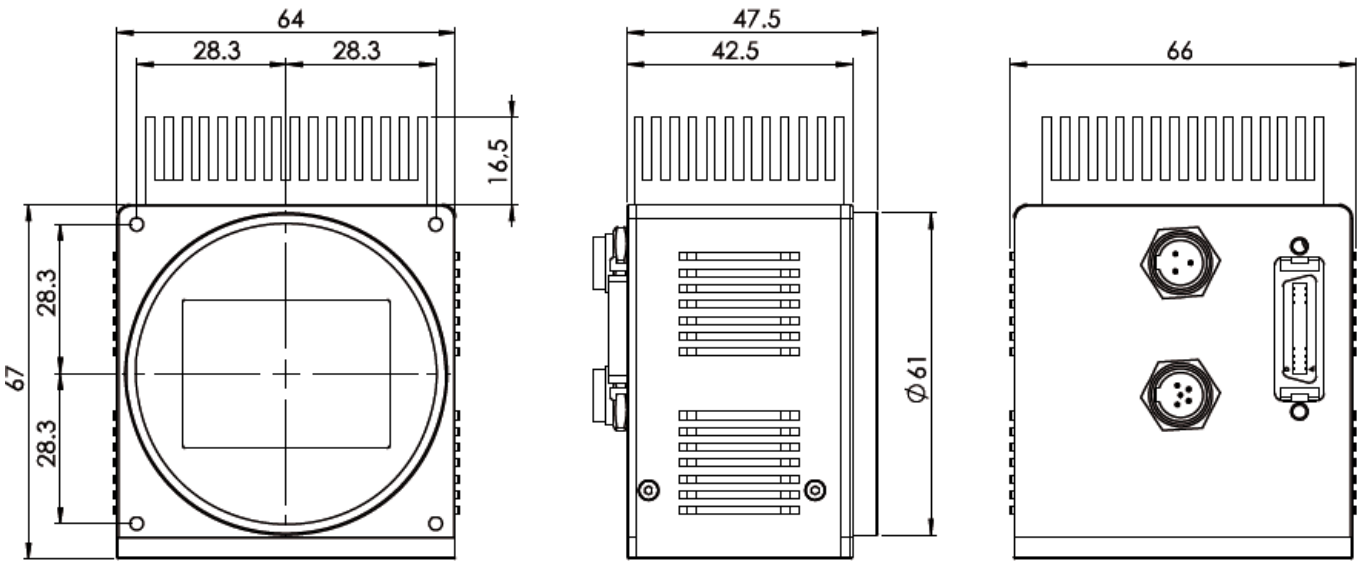

**View on mounting side svs11002**

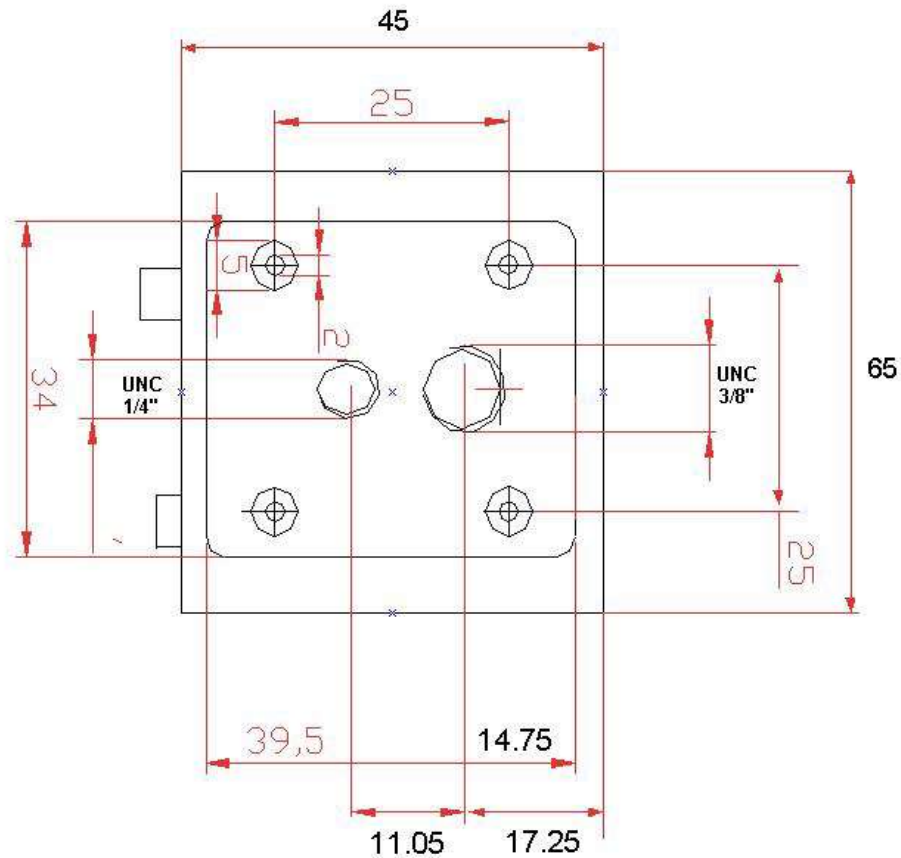



**Views on svs16000 “S”, ”O” and “F” Version (no heatsink)**

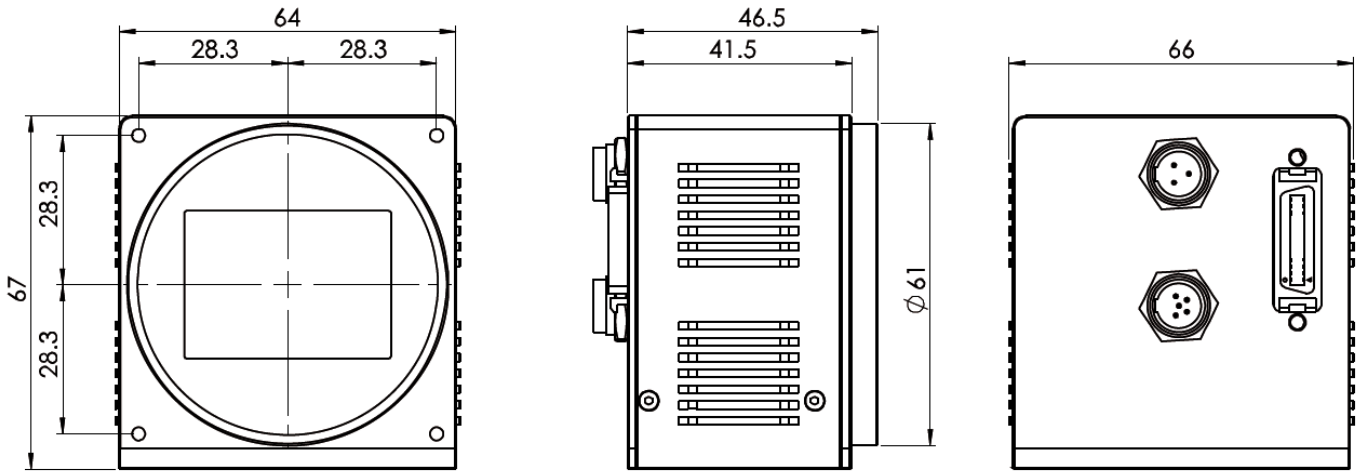

**Distance from Chip surface to front plate: 11,65mm**

MDR 26 female Connector  
 Sync and Dataserial LVDS  
 see Listing on 2.4.2  
 Mating connector:  
 3M

Part.-Nr of connector: 10126-6000EL  
 Part.-Nr of hood: 10326-A200-00

Power Connector:  
 Pin 1: + 12V  
 Pin 3: GND  
 Pin 2: Reserved  
 Mating connector: Switchcraft TA3F

Trigger Connector:  
 Pin 4: TTL – (GND)  
 Pin 5: TTL +  
 Pin 1, 2, 3: Do Not Connect  
 Mating connector: Switchcraft TA 5F

**Views on svs16000 “U” Version with heatsink**

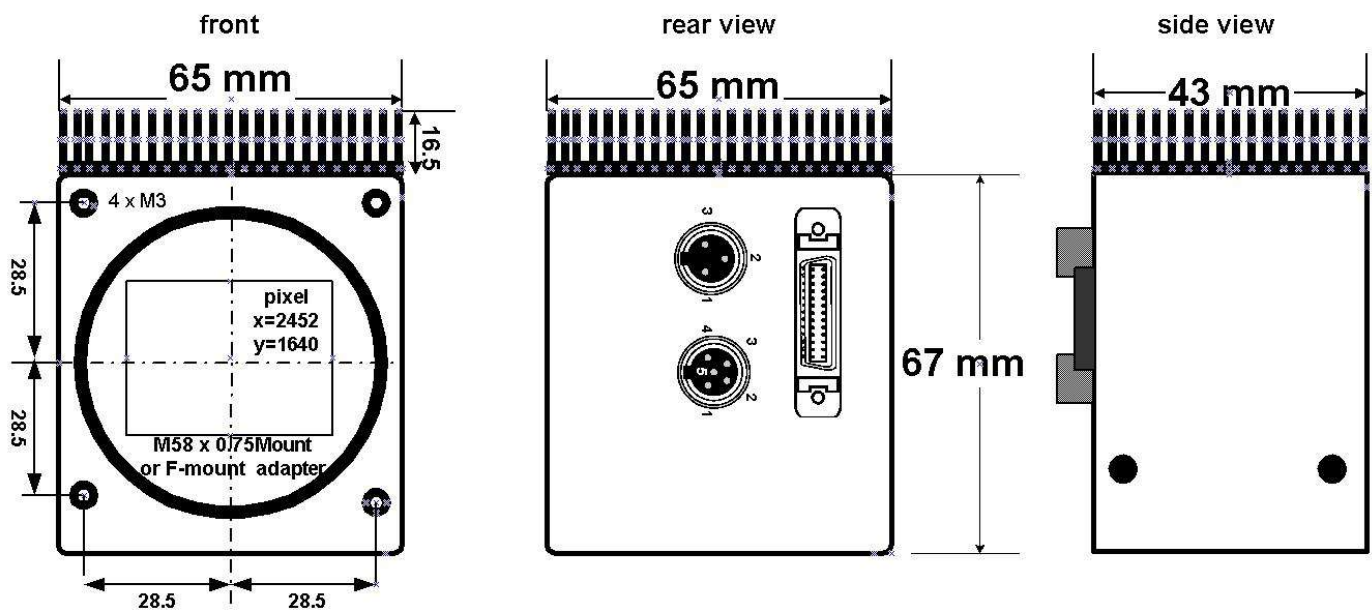

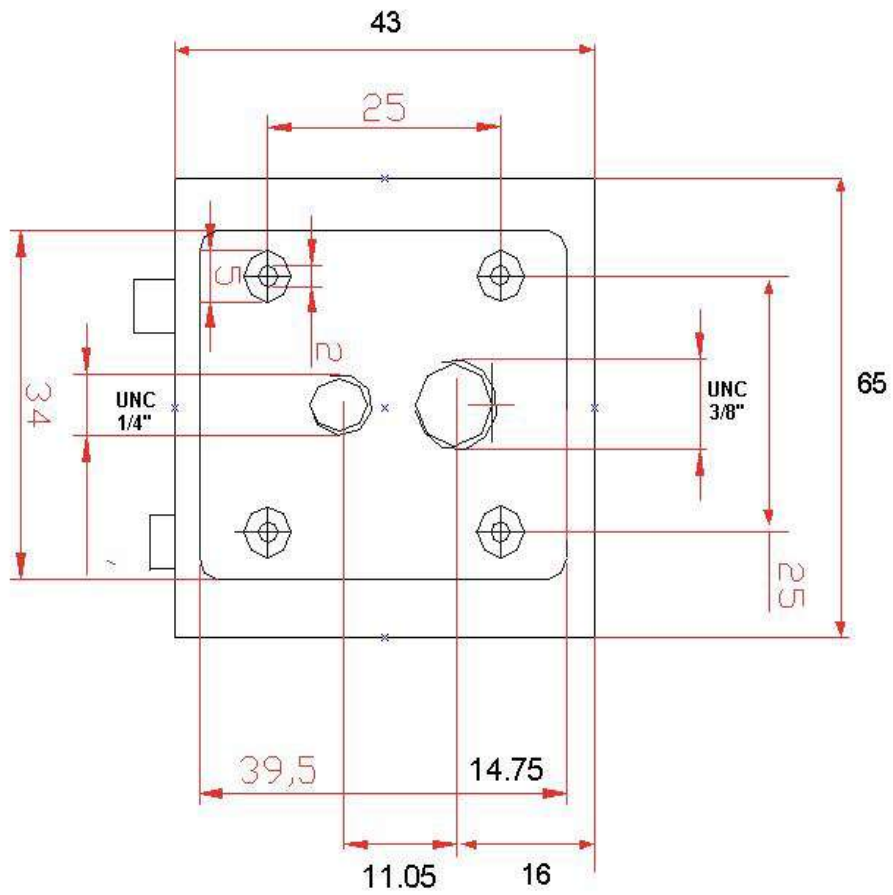
**View on mounting side svs16000**

### 3.5 Basic electro-optic specifications svs11002 “U” version

CCD KAI 11002 Interline	4032 x 2672 pixel	pixel size 9 x 9 $\mu$ m
Readout frequency	2 x 48 MHz (2 taps)	
Frame rate (max.)	7.5 fps	
Offset	ca. 10 counts	
Gain	1 to 2	
S/N ratio	8-Bit (Saturation/Dark Noise (RMS)) Color version 8-bit	
Fixed Pattern Noise	+/- 2 counts	
Photo Response Nonuniformity (PRNU)	+/- 10%	
Spectral response	380 - 950 nm	
Exposure time (mode 2)	256 $\mu$ sec - 5.5 sec	
Leading dark lines	18	

### Basic electro-optic specifications svs11002 “F” version

CCD KAI 11002 Interline	4008 x 2672 pixel	pixel size 9 x 9 $\mu$ m
Readout frequency	2 x 30 MHz (2 taps)	
Frame rate (max.)	4.7 fps	
Offset	ca. 10 counts	
Gain	1 to 2	
S/N ratio	8.5-Bit (Saturation/Dark Noise (RMS)) Color version 8-Bit	
Fixed Pattern Noise	+/- 2 counts	
Photo Response Nonuniformity (PRNU)	+/- 10%	
Spectral response	380 - 950 nm	
Exposure time (mode 2)	409 $\mu$ sec - 8.97 sec	
Leading dark lines	18	

**Basic specifications of camera svs11002 “S” version**

CCD KAI 11002 Interline	4032 x 2672 pixel	pixel size 9 x 9 $\mu\text{m}$
Readout frequency	1 x 30 MHz (1 tap)	
Frame rate (max.)	2.5 fps	
Offset	ca. 10 counts	
Gain	1 to 2	
S/N ratio	9-Bit (Saturation/Dark Noise (RMS)) Color version 8-Bit	
Fixed Pattern Noise	+/- 2 counts	
Photo Response Nonuniformity (PRNU)	+/- 10%	
Spectral response	380 - 950 nm	
Exposure time (mode 2)	818 $\mu\text{sec}$ - 9 sec	
Leading dark lines	18	

**Basic specifications of camera svs11002 “L” version (12-Bit)**

CCD KAI 11002 Interline	4032 x 2672 pixel	pixel size 9 x 9 $\mu\text{m}$
Readout frequency	Up to 2 x 48MHz (2 tap)	
Frame rate (max.)	<b>7.5 fps</b>	
Offset	ca. 40 counts@12 bit	
Gain	1 to 2	
S/N ratio	10,5-Bit (Saturation/Dark Noise (RMS)) Color version 10-Bit	
Fixed Pattern Noise	+/- 8 counts	
Photo Response Nonuniformity (PRNU)	+/- 10%	
Spectral response	380 - 950 nm	
Exposure time (mode 2)	170 $\mu\text{sec}$ - 10 sec	
Leading dark lines	15	

**Basic specifications of camera svs11002 “H” version (12-Bit)  
2 x 64 MHz**

CCD KAI 11002 Interline	4032 x 2672 pixel	pixel size 9 x 9 $\mu\text{m}$
Readout frequency	Up to 2 x 64 MHz (2 tap)	
Frame rate (max.)	<b>10 fps</b>	
Offset	ca. 40 counts@12 bit	
Gain	1 to 2	
S/N ratio	9,0 -Bit (Saturation/Dark Noise (RMS))	
Fixed Pattern Noise	+/- 8 counts	
Photo Response Nonuniformity (PRNU)	+/- 10%	
Spectral response	380 - 950 nm	
Exposure time (mode 2)	202 $\mu\text{sec}$ – 8 sec	
Leading dark lines	15	

**Basic electro-optic specifications svs16000 “F” version**

CCD KAI 16000 Interline	4904 x 3280 pixel	pixel size 7,4 x 7,4 $\mu\text{m}$
Readout frequency	2 x 30 MHz (2 taps)	
Frame rate (max.)	3 fps	
Offset	ca. 10 counts	
Gain	1 to 2	
S/N ratio	8.5-Bit (Saturation/Dark Noise (RMS)) Color version 8-Bit	
Fixed Pattern Noise	+/- 2 counts	
Photo Response Nonuniformity (PRNU)	+/- 10%	
Spectral response	380 - 950 nm	
Exposure time (mode 2)	120 $\mu\text{sec}$ - 8 min (if useful)	
Leading dark lines	40	

**Basic electro-optic specifications svs16000 “U” version**

CCD KAI 16000 Interline	4904 x 3280 pixel	pixel size 7,4 x 7,4 $\mu\text{m}$
Readout frequency	2 x 48 MHz (2 taps)	
Frame rate (max.)	4,7 fps	
Offset	ca. 10 counts	
Gain	1 to 2	
S/N ratio	10-Bit (Saturation/Dark Noise (RMS)) Color version 8-Bit	
Fixed Pattern Noise	+/- 2 counts	
Photo Response Nonuniformity (PRNU)	+/- 10%	
Spectral response	380 - 950 nm	
Exposure time (mode 2)	120 $\mu\text{sec}$ - 8 min (if useful)	
Leading dark lines	40	

### Basic electro-optic specifications svs16000 “L” version

CCD KAI 16000 Interline	4904 x 3280 pixel	pixel size 7,4 x 7,4 µm
Readout frequency	Up to 2 x 48MHz (2 taps)	
Frame rate (max.)	4,8 fps	
Offset	ca. 40 counts@12 bit	
Gain	1 to 2	
S/N ratio	9,5 -Bit (Saturation/Dark Noise (RMS)) Color version 8-Bit	
Fixed Pattern Noise	+/- 8 counts	
Photo Response Nonuniformity (PRNU)	+/- 10%	
Spectral response	380 - 950 nm	
Exposure time (mode 2)	250 µsec - 8 min (if useful)	
Leading dark lines	40	

### 3.6 Environmental Testing:

#### 3.6.1 Europe

The camera is CE tested and the rules of EN 50022-2 apply.

#### 3.6.2 USA and Canada

I. Labeling requirements:

This device complies with part 15 of the FCC Rules. Operation is subject to the following two conditions: (1) This device may not cause harmful interference, and (2) this device must accept any interference received, including interference that may cause undesired operation.

II. Information to the user:

Note: This equipment has been tested and found to comply with the limits for a Class A digital device, pursuant to part 15 of the FCC Rules. These limits are designed to provide reasonable protection against harmful interference when the equipment is operated in a commercial environment. This equipment generates, uses, and can radiate radio frequency energy and, if not installed and used in accordance with the instruction manual, may cause harmful interference to radio communications. Operation of this equipment in a residential area is likely to cause harmful interference in which case the user will be required to correct the interference at his own expense.

Camera complies with FCC Form 47 Rules.

 **It is necessary to use a shielded power supply cable which has GND contact to the camera housing. This is essential for any use. If not done and camera is destroyed due to Radio magnetic Interference (CE, RMI) WARRANTY is void!**

**Operating temperature Spec.:** -10 - +40°C. In order to keep dark current low. To achieve 8.5 optical bits, operation at 25° max. is recommended.

**Shock** is tested about 30 g in 6 ms. **Vibration test** is 10 g in 6 ms.

**Power:** US/UK and European line adapter can be delivered. Otherwise use + 12V DC with filtered and stabilized power supply.

**RoHS:** All cameras comply with the recommendation of the European Union concerning **RoHS Rules**.

### 3.7 Spectral response curves

Monochrome Version svs11000/16000

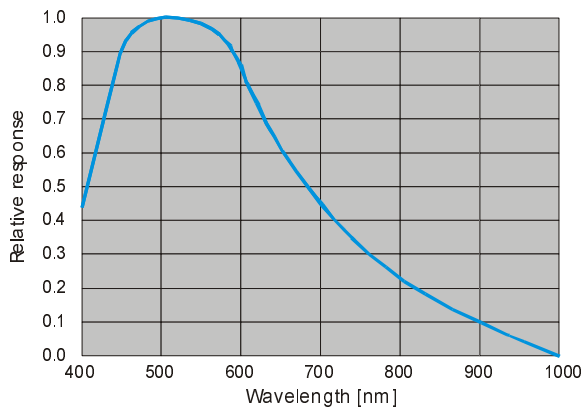

All Color Versions

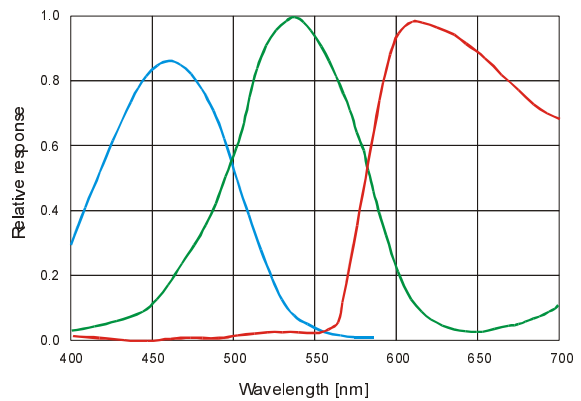

**For special configuration like no micro lens or window less CCD consult your local dealer**



### 3.8 Comments on camera temperature

Higher case temperature is noticed. There is no need to worry because camera has been tested at higher temperature than specified (40 °C). However some components inside like CCD, ADC, drivers are pushed to their limits. **In order to take advantage of the speed of the “U” +”H” (Ultra + High Speed” version) it must be operated with forced air cooling. It means a gentle airflow not causing vibrations! This will help to extend life time of the camera**

**Note that Warranty will be void if you don't follow these instruction for “U” version!**

#### Recommended setup:

Recommended Airflow for "U"  
Type of cameras  
(One air stream is sufficient)

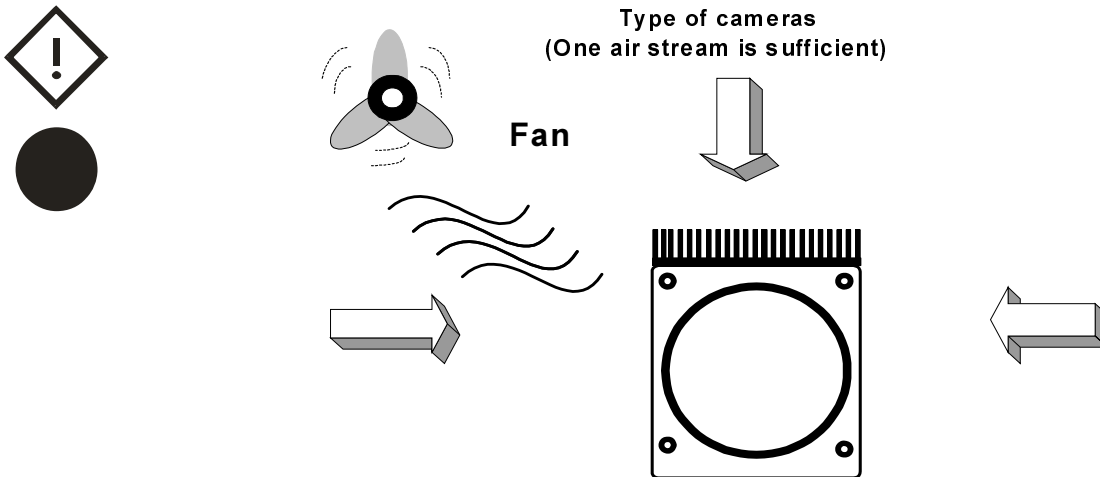

**Note that a customized version with heatsink AND integrated fan is available upon request**

### 3.9 Comments on COLOR Version

If you have purchased a COLOR version of this camera, please note the following:

In all electrical terms the camera is identical to the black and white versions. The output is parallel or CameraLink but the color pixel are transferred in series from the camera.

The camera uses a CCD which has a color mosaic filter. This filter is called "Bayer" filter named after the person who invented it. It has a pattern on the lines which alternates as follows:

E.g.: First line: RGRGRG ... and so on. (R = RED, B = BLUE, G = GREEN)

Second line: GBGBGB ... and so on.

Please note that about half of the pixel are green, a quarter red and a quarter blue. This is due to the maximum sensitivity of the human eye at about 550 nm (green).

Because this camera is a single chip camera it is necessary to use an algorithm which interpolates those colors which are "not known" by the specific pixel. E.g. the red pixel does not know its green and blue components.

This means that the performance of the image depends on the software used.

Please be aware that it is not possible to incorporate the algorithm into the camera so easily. Unlike NTSC/PAL cameras there is no hardware chip available which can do that for such large images. The user has the advantage to alter the colors depending on his needs. Thus the color image must be processed in the PC. A color source code is available on request.

We offer a complete set for a system setup containing camera, cable, power supply, framegrabber and software to help solving your applications.

If you have questions do not hesitate to contact us or your local dealer.

## 4.0 Proven Interfacing to Framegrabbers

These framegrabbers have been adapted to cameras mentioned in this manual successfully:

### svs11002

**EURESYS:** Grablink Value/Expert/Express

**DALSA/CORECO:** PC-CamLink  
X64 CameraLink/X64 I-PRO

**NATIONAL INSTRUMENTS:** 1426, 1428, 1429

**Cognex:** 8601 (1 tap), 8602 (2 tap)

**Matrix Vision** mvTitan CL

### svs16000

**EURESYS:** Grablink Value/Expert/Express

**Bitflow** NeonCL , CarbonCl

**Please check individual camera types with framegrabber manufacturer!**

#### 4.1 Warranty Terms

Standard products warranty and adjustment. Seller warrants that the article to be delivered under this order will be free from defects in material and workmanship under normal use and service for a period of **TWO** years from date of shipment. The liability of Seller under this warranty is limited solely to replacing or repairing or issuing credit (at the discretion for Seller) for such products that become defective during the warranty period. In order to permit Seller to properly administer this warranty, Buyer shall notify Seller promptly in writing of any claims,; provide Seller with an opportunity to inspect and test the products claimed to be defective. Such inspection may be on customer's premises or Seller may request return of such products at customer's expense. Such expense will subsequently be reimbursed to customer if the product is found to be defective and Buyer shall not return any product without prior return authorization from Seller. If a returned product is found to be out of warranty or found to be within the applicable specification, Buyer will have to pay an evaluation and handling charge, independent of possible repair and/or replacement costs. Seller will notify Buyer of the amount of said evaluation and handling charges at the time the return authorization is issued. Seller will inform Buyer of related repair and/or replacement costs and request authorization before incurring such costs. Buyer shall identify all returned material with Sellers invoice number, under which material has been received. If more than one invoice applies, material has to be clearly segregated and identified by applicable invoice numbers. Adjustment is contingent upon Sellers examination of product, disclosing that apparent defects have not been caused by misuse, abuse, improper installation of application, repair, alteration, accident or negligence in use, storage, transportation or handling. In no event shall Seller be liable to Buyer for loss of profits, loss of use, or damages of any kind based upon a claim for breach of warranty.

Development Product Warranty. Developmental products of Seller are warranted to be free from defects in materials and workmanship and to meet the applicable preliminary specification only at the time of receipt by Buyer and for no longer period of time in all other respects the warranties made above apply to development products.

The aforementioned provisions do not extend the original warranty period of any article which has been repaired or replaced by Seller. If Warranty Label of camera is broken Warranty is void!

SELLER MAKES NO OTHER WARRANTIES; EXPRESS OR IMPLIED; AND SPECIFICALLY; SELLER MAKES NO WARRANTY OF MERCHANTABILITY OF FITNESS FOR PARTICULAR PURPOSE.

## Appendix A – Troubleshooting

**Problem:** Camera does not respond to light

**Solution:** Please execute following steps

Check if camera is in mode 0). Thus: Free running with serial exposure ctrl. When done, check with “Convenient Cam “program if you can read back any data from the camera like : Mode, type of CCD, exposure time settings and so on.

If Mode 0) works check the signals of the camera in the desired operation mode like 1) or 2). In these modes check if the Exsync signal is present. Please note that a differential signal must be fed to the connector. The typical signal swing for LVDS must be about 250 mV. Below such level the drivers in the camera will not work. If you use a TTL level signal fed to the TB 5 connector check the quality and swing. If these signals are not there or don't have the right quality the camera can not read out any frame (mode 1 and 2).

**Problem:** Image is present but distorted:

**Solution:** Check the camera configuration file of your framegrabber. Check number of “front- and back porch pixel”. Wrong numbers in configuration file can cause sync problems. Check if your framegrabber can work with the data rate of the camera.

**Problem:** The image of a color version camera looks “ugly” or false colors appear.

**Solution:** If the raw image looks OK check the camera file to see if the pixel need to be shifted by either one pixel or one line. The image depends on the algorithm used. If the algorithm is starting with the wrong pixel such effects appear.

**Problem:** The colors of a color version are not perfect especially when using a halogen light.

**Solution:** Halogen light contains strong portions of IR radiation. Use cut off filters at around 730 nm like Schott KG 3 to prevent IR radiation reaching the CCD.

**Problem:** No serial communication is possible between the camera and the PC (CameraLink)

**Solution:** Check if your Microsoft ® Dot Net Framework 2.0 installation was successful. Than: Use “load camera DLL” and try again.



---

## TROUBLESHOOTING REQUEST LIST V1.1

**Dear valued customer,**

In order to help you with your camera and any interfacing problems we request that you fill in a description of your problems when you use the camera. Please fax this form to us:

- 1) Type of camera (e.g. svs11000XXCP)
- 2) Serial Number
- 3) Accessories used and where purchased or self made
  - a) Power supply
  - b) Cable
  - c) Lens type and focal length
- 4) Firmware version as well as operation mode, (send screenshot of ConvCam program)
- 5) Description of the phenomena, e.g.:
  - a) Missing lines or columns
  - b) Distorted or noisy image (if possible send jpg image)
  - c) Solarization effect
  - d) Missing bits, contrast less image
- 6) Framegrabber used: Brand and type
- 7) IN CASE OF EURESYS FRAMEGRABBER ONLY:
  - a) Driver version used
  - b) Camera file used
  - c) Operating system used e.g. WIN XP

## Appendix B – Basic timing for different operation modes

### Notes:

The fundamental signals are PVAL (STROBE), LVAL and FVAL, and in case of triggered modes, Exsync.

### Mode 0: Free running using RS 232 Interface

A frame is readout automatically and the data are valid indicated by LVAL per line and FVAL by frame. The data is valid at the rising edge of PVAL (Strobe). The frame rate is about 13 fps and there is no need to trigger the camera in order to get data. The enclosed software allows the user to set exposure time from 60  $\mu$ sec to 60 msec. The time set stays resident after power off if the configuration is saved to EEPROM.



### Mode 1: External Trigger and Pulswidth of EXSYNC

In this mode the camera is waiting for an external trigger which starts integration and read out. Exposure time can be varied using the length of the EXSYNC pulse (i.e. between the high going edge and the low going edge). The time settings in the control software are not activated. This mode is useful in applications where the light level of the scene changes during operation and the framegrabber can provide such a signal. Change of exposure time is possible from one frame to the next.

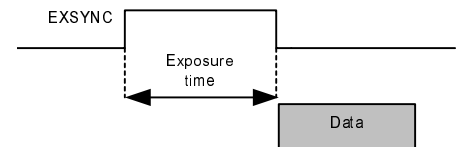

### Mode 2: External trigger and RS 232 Interface

The frame rate is determined by the number of EXSYNC pulses per time unit. With each positive transition (going high) the camera will readout a frame. Exposure time is set in the same way as in the free running mode but with an exposure range from 60  $\mu$ sec to 4,3 sec. Exposure time can be changed online during operation. No frame is distorted during switching time. The time set stays resident after power off, if the configuration is saved to EEPROM.

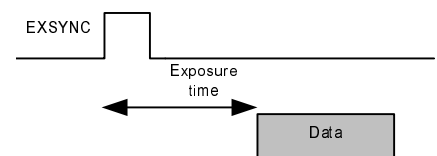

• Freerunning

■ Pixel Timing

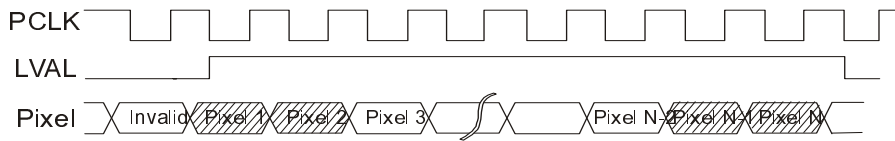

■ Line Timing

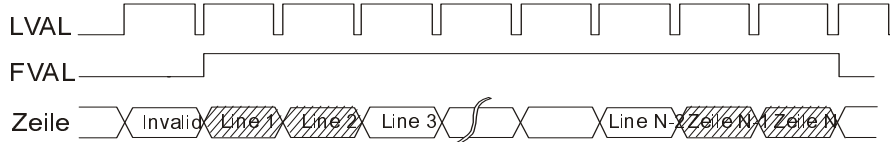

■ Triggered/Internal Exposure

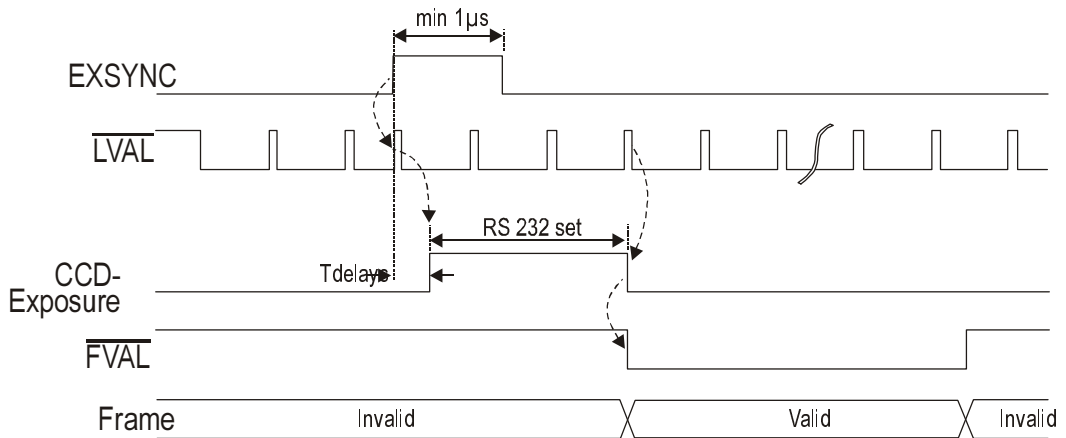

Tdelay min 25 max 15 µSec ("S"+ "F") Tdelay min 10 max 25µSec ("U" version)

■ Triggered/External Exposure

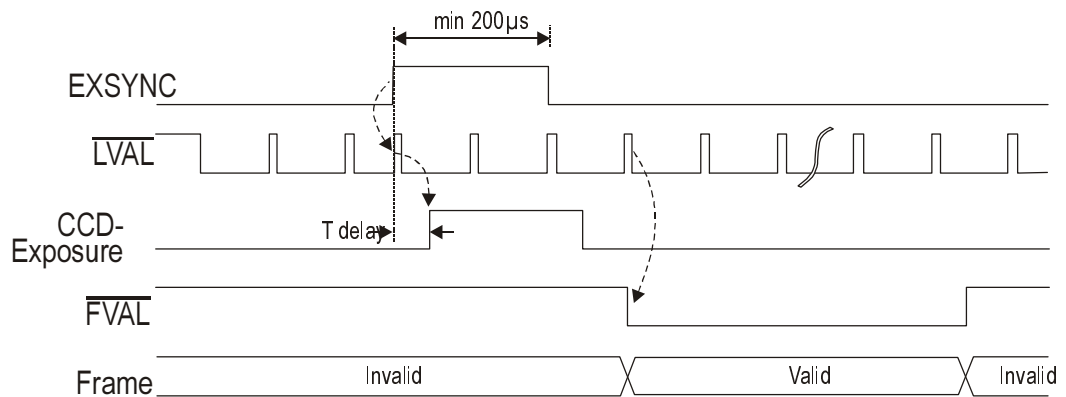

Tdelay Min 32 max 50 uSec ("S" + "F" version) Min 10 max 25 ("U" version)



## Appendix C: Code Description for serial Camera Control

This description is useful for those who need to integrate the camera control into an application and who cannot make use of the **Convenient Cam** program.

### 1. Hardware

All commands to configure the camera are made using the serial CameraLink interface.

### 2. Protocol

Baudrate: 9600,

8 Databit, 1 Stopbit, no parity, no Handshake

When camera is powered on the following message will be displayed:

“KAI 11002 (or other sensor resp.) < 0 x 0 d, 0 x 0 a>”

### 3. Commands

The ENTER command can be activated either by “0 x 0 d, 0 x 0 a“ or by single “0 x 0 a“.

Valid tap numbers (Channelnumbers) are 1 or 2.

If correct the camera will respond with: “OK < 0 x 0 d, 0 x 0 a>“.

If not correct it will respond “Error<0 x 0 d, 0 x 0 a>“.

All numbers must be typed as hexadecimal values (hexvalues).

The command strings are case sensitive.

#### 4.1 Accessible commands for the end user:

“C<ENTER>“: Output of camera status, e.g.:

```

KAI11000           ; Sensor Type
Gain1: 00AE       ; gain tap 1
Gain2: 00A9       ; gain tap 2
Offset1 000A      ; offset value tap1
Offset2: 0008     ; offset value tap2
CamMode: 0000     ; operation mode
Expocounter: 0400 ; exposure time
ControlReg2: 0002 ; ADC configuration, not changeable by user
ControlReg1: 0184 ; ADC configuration, not changeable by user
BlackCount: 000A ; ADC configuration, not changeable by user
CDSDelayReg: 0036 ; ADC configuration, not changeable by user
ADCDelayReg: 0000 ; ADC configuration, not changeable by user
SubstratV: 0038   ; Substrat voltage, not changeable by user
DumpCount: 0000   ; dump count for partial scan
Frames/s: 0010    ; Framerate
Lines/s: 804E     ; Linerate
OK

```

"I<ENTER>": out put of factory (default) data (like ser. # of product)

```
KAI11002
Serial no.: 0527
Hardware version 1.0
Firmware version 1.0
Software version 1.0
Gain1: 007C      ; factory setting gain tap 1(= gain factor 1.0)
Gain2: 0077      ; factory setting gain tap 2 (= gain factor 1.0)
Offset1: 0008    ; factory setting offset tap 1
Offset2: 0008    ; factory setting offset tap 2
OK
```

"O<Channelnr.>, <Hexvalue><ENTER>":  
Input of dark offset for the appropriate output tap  
0.3FF

"G<Chanelnr.>, <Hexvalue><ENTER>":  
Input of gain for the appropriate output tap  
0.2FF, gain = n \* 0.045dB

"T<Hexvalue><ENTER>":  
Input of exposure time in line times  
0.FFFF in triggered mode  
0.815 in free running mode, exposure time in line times  
is 816 (= line count of one frame) - n

"D<Hexvalue><ENTER>":  
Input of amount of lines which are dumped out (partial scan mode)  
0,2 14 A  
0 = no partial scan  
1 = not allowed  
2 = 2 \* 15(decimal) lines dumped out  
n = n \* 15(decimal) lines dumped out  
  
valid lines = 2704 - (n \* 15)  
n = (2672 - valid lines)/15  
(formula with decimal values)

"S<ENTER>": safes actual configuration to EEPROM

"R<ENTER>": camera reset, output of status message

"M<Hexvalue><ENTER>": Input of operation mode

**Following values are true:**

- 0 x 00: free running mode, no binning
- 0 x 01: triggered mode, exposure time via external signal (Exsync), no binning
- 0 x 02: triggered mode, exposure time via Micro controller
- 0 x 03: reserved
- 0 x 04: free running mode, horizontal binning only;
- 0 x 05: triggered Mode, exposure time via external Exsync, horizontal binning only
- 0 x 06: triggered mode, exposure time via Micro controller, horizontal binning only
- 0 x 07: reserved
- 0 x 08: free running mode, vertical binning only for 2 lines;
- 0 x 09: triggered mode, exposure time via external Exsync, vertical binning only for 2 lines
- 0 x 0A: triggered mode, exposure time via Microcontroller, vertical binning only for 2 lines
- 0 x 0B: reserved
- 0 x 0C: free running mode, horizontal and vertical binning for 2 lines
- 0 x 0D: triggered mode, exposure time via external Exsync horizontal and vertical binning for 2 lines
- 0 x 0E: triggered mode, exposure time via Micro controller, horizontal and vertical binning for 2 lines
- 0 x 0F: reserved
- 0 x 10 – 0 x 19: Do not use
- 0 x 1B: Do not use
- 0 x 1C: Do not use
- 0 x 1D: Do not use
- 0 x 1E: Do not use
- 0 x 1F: Do not use

It is further possible to configure Exsync by using bit 5. Result is a change from the differential trigger to the TTL input trigger.

**Overview over mode bits**

Bit	7	6	5	4	3	2	1	0
<b>= 1</b>	Slow Mode	Reserved always 0	Exsync via TTL-input	Reserved always 0	2 x 2 binning	2 x 2 binning	triggered mode, exposure time via Micro controller	triggered mode exposure time via Exsync pulsewidth

**For PIV mode of all cameras using 14 bit ADC ( 12 bit output):**

activate by bit 6:

Mode-byte bit 6: PIV Mode enable

1 = PIV Mode on

0 = PIV Mode off (normal operation)

## Appendix D

### Note on CameraLink Software DLL:

#### Serial (RS232) Interface to CameraLink Framegrabbers using CameraLink DLL:

If Interface is made according to CameraLink standard:

The software does not communicate via RS 232 port of the PC but via clser\*.dll-Interface.

#### CameraLink standard 1.0:

This is the Interface defined by "CameraLink" specification and the framegrabber manufacturer should offer/use a clser\*.dll to communicate with.(The star "\*" indicates the specific code of the FG manufacturer).

#### CameraLink standard 2.0:

In CameraLink standard version 2.0 is a DLL called clallserial.dll which allows automatically to load the correct framegrabber specific DLLs. If framegrabber does not support version 2.0 than delete clallserial.dll and use version 1.0.

#### OPERATION:

- After starting ConvCam simply click "OK" on error message. This is due to not cleared "communication path" of the RS232 and it must be initiated.
- for CameraLink standard 1.0 only:
  - Click on "Configuration"
  - Open "CamlinkDLL" (File browser will open)
  - Choose sub directory where clser\*.dll is located. For example: For EURESYS (usually C:\WINNT\system32\), "clseremc.dll".
- Set COM-Port to the appropriate number ("1" for the first CameraLink connector, "2" for the second connector a.s.o.).
- Click on ReadStatus.

If there is still a problem contact us.

Appendix E

**Safety Instructions**

- This section contains important information for the operator (user) and/or people around him/her to avoid personal injuries, or property damages against him/her or people around him/her by using this product correctly.
- Prior to use, read this section carefully to fully understand its instructions for correct use.

**Definition of markings**





The meaning of each mark used in this instruction manual is given below

DANGER	This mark warns the user that improper use, indicated with this mark, may cause death or severe personal injuries against the user or people around him/her.
CAUTION	This mark warns the user that improper use, indicated with this mark, may cause personal injuries (*1) or material damages (*2) against the user or people around him/her.





Notes



- \*1: Personal injuries mean wounds, burns, electric shocks, and others for which the person injured needs neither to be hospitalized nor to be cared for the long term.
- \*2: Material damages means any direct or consequential damages related to property or material loss.



	This mark indicates what the user SHOULD NOT DO. The details of things, which the user should not do, are described next to this mark.
	<input type="checkbox"/> <input type="checkbox"/> This mark indicates what the user MUST DO. The details of things, which the user must do, are described next to this mark.
	This mark indicates that the user must be alert against a possible DANGER. The details of the DANGER, which the user must be aware of, are described next to this mark.
	<input type="checkbox"/> <input type="checkbox"/> This mark indicates that the user is given a CAUTION against possible hazards. The details of the CAUTION, which the user must be aware of, are described next to this mark.

 Handling Precautions

 <p><b>DANGER</b></p>	
	<p><u>If any overheating sign is observed, discontinue the use immediately.</u>                  In the event that smoke, smell, or any other overheating sign is observed, turn the power switch of the system OFF immediately and remove the power cable(s) from the system connectors, like computer, camera, and lightning. Do NOT try to continue to use the system. To do so in spite of clear signs of malfunction invites a fire, an electric shock hazard, or a serious damage to the system components. In such case, contact for repair service us or our dealer/distributor, from which you purchased the system.</p>
	<p><input type="checkbox"/> <u>If any malfunctioning sign is observed, discontinue the use immediately.</u>                  Do NOT try to use the system when it is malfunctioning. (Ex. No images on the monitor) In the event of malfunction, turn the power switch of the system OFF immediately and remove the system power cables from the system components connectors. In such case, contact for repair service us or our dealer/distributor from which you purchased the system.</p>
	<p><input type="checkbox"/> <u>If any foreign object gets into the system components, discontinue the use immediately.</u>                  In the event that liquids, small particles, or any other foreign objects get into the system components, do NOT try to continue to use the system. To do so invites a fire</p>

	or an electric shock hazard. In that case, turn the power switch of the system components OFF immediately and remove the system power cables from the system components connectors. After that, contact us or our dealer/distributor from which you purchased the camera for repair service/technical advice.
	<input type="checkbox"/> <u>Do NOT disassemble the system components.</u> Do NOT attempt to pull apart; repair, or modify the system components on your own. To do so leads to a fire or an electric shock accident. Contact us or the dealer/distributor from which you purchased the camera for repair/modification.
	<input type="checkbox"/> <u>Do NOT supply any power than specified.</u> The system components are designed to work only under specified voltage. Do NOT attempt to drive the system components with the power other than specified. Operating the system components under power other than specified invites a fire or an electric shock hazard.
	<input type="checkbox"/> <u>Do NOT use the system components in a high-humidity environment.</u> Do NOT place the system components near a humidifier, or in other high-humidity environment. To do so may cause a fire or an electric shock accident.

**CAUTION**

	If the system components are operated in the electromagnetic field, there may be cases where noises (vertical, horizontal, or oblique stripes) may appear to a video output or causes other malfunctions. In that case, take preventive measures on the electromagnetic-wave generating source so that the system components do not receive the interference by the electromagnetic-wave. Take extra precautions against electromagnetic-wave-interference if the system components are used with a servomotor, inverter, or other electromagnetic-wave-generating equipment.
	Avoid giving a strong shock against the system components. If your system components are used in the system where the connectors are subjected to strong repetitive shocks, the connector are possible to break down. If you intend to use your system components in such a situation, make sure to use an optional-connector-fixing-hardware to connect the connector-plug to the system components body.
	When the system components are not in use, put a lens or a lens-cap onto the cam head so that the image pickup plane of CCD is protected from dust, foreign object, or other flaw-causing object. If the glass plane (image pickup plane) gets dirty, clean it with a cotton swab. When it needs to be cleaned with a cleaner, be sure NOT to use any organic solvent other than ethyl alcohol. Do not clean the other system components. In such a case call us or the dealer/distributor from which you purchased the system components for cleaning or cleaning instructions. As a countermeasure against condensation, when the system components are moved from a warm place to a cold place, take appropriate precautions to prevent condensation from forming on the system components.
	Do not pull strongly the any cable nor swing it. The stress from pulling or swinging may cause damage in the coating of the cable, or breaks in the inside wires.
	Avoid short-circuiting its signal output. Otherwise, the system components might be damaged.
	If too much amount of light, (= the incoming light amount of 100 times or greater in comparison with standard light) enters CCD image pickup plane, video output might not be obtained. In such a case, take measures to reduce the amount of incoming light.
	Do NOT expose the camera to intensive light (sunlight, etc.) to prevent its inner CCD from getting damaged.
	When mounting a lens, take extra caution so that the lens is not tilted, nor does flaw exist at the lens-mount-screw part. Also check to confirm that neither dirt nor other foreign object is put inside. Improper mounting might cause the parts to become locked.



Do NOT use any optional unit other than manufacturer-supplied one. We disclaim any responsibility for damages or losses incurred by user due to the use of unauthorized/unofficial option units supplied by a third party

#### RESTRICTION FOR USE

In case malfunction of this equipment (e.g. video output cut-off) can be expected to lead to significant accident, avoid using this equipment for such system integration use.

#### CASES FOR INDEMINITY (LIMITED WARRANTY)

We shall be exempted from taking responsibility and held harmless for damages or losses incurred by user in the following cases. In case damages or losses are caused by fire, earthquake, or other acts of Gods, the act by third party, misuse by the user deliberately or erroneously, use under extreme operating conditions.

- In case indirect, additional, consequential damages (loss of expected interest, suspension of business activities) are incurred as results of malfunction of non-function of the equipment, we shall be exempted from assuming responsibility for such damages.
- In case damages or losses are caused by incorrect use, which is not in line with the instructions in this instruction manual.
- In case damages or losses are caused by malfunction resulting from band connection with other equipment.
- In case damages or losses are caused by repair or modification done by the user.

#### IMPORTANT SAFETY INSTRUCTIONS

1. This device is designed and guaranteed to work under the temperature range of - 10 through 45 degree C. Avoid using the equipment beyond that limits.
2. Do NOT expose the camera's image-pickup-plane to sunlight or other intense light directly. Its inner CCD (charge-coupled device) might be damaged.
3. Do NOT exposure all system components to sunlight or other intensive light (UV, IR).
4. In the event that any abnormal condition is observed, turn the power switch OFF immediately. Do NOT try to continue to use the system components. To do so in spite of clear signs of malfunction invites a fire, an electric shock hazard, or any other serious damage to the system components. In such case, contact us or our dealer/distributor that you purchased the system components from for repair service.
5. To clean the body of this equipment, make sure to turn all power switches OFF first. To remove stubborn stains, use a soft cloth soaked in diluted acid free detergent. After that, clean with a dry cloth.
6. In case the image-pickup-plane should be settled with fine dust, dirt, or scratched, ask our distributor for technical advice